

Oct. 29, 1935.

R. R. BOWSER ET AL

2,018,943

LIQUID DISPENSING CONTAINER

Filed Jan. 2, 1935

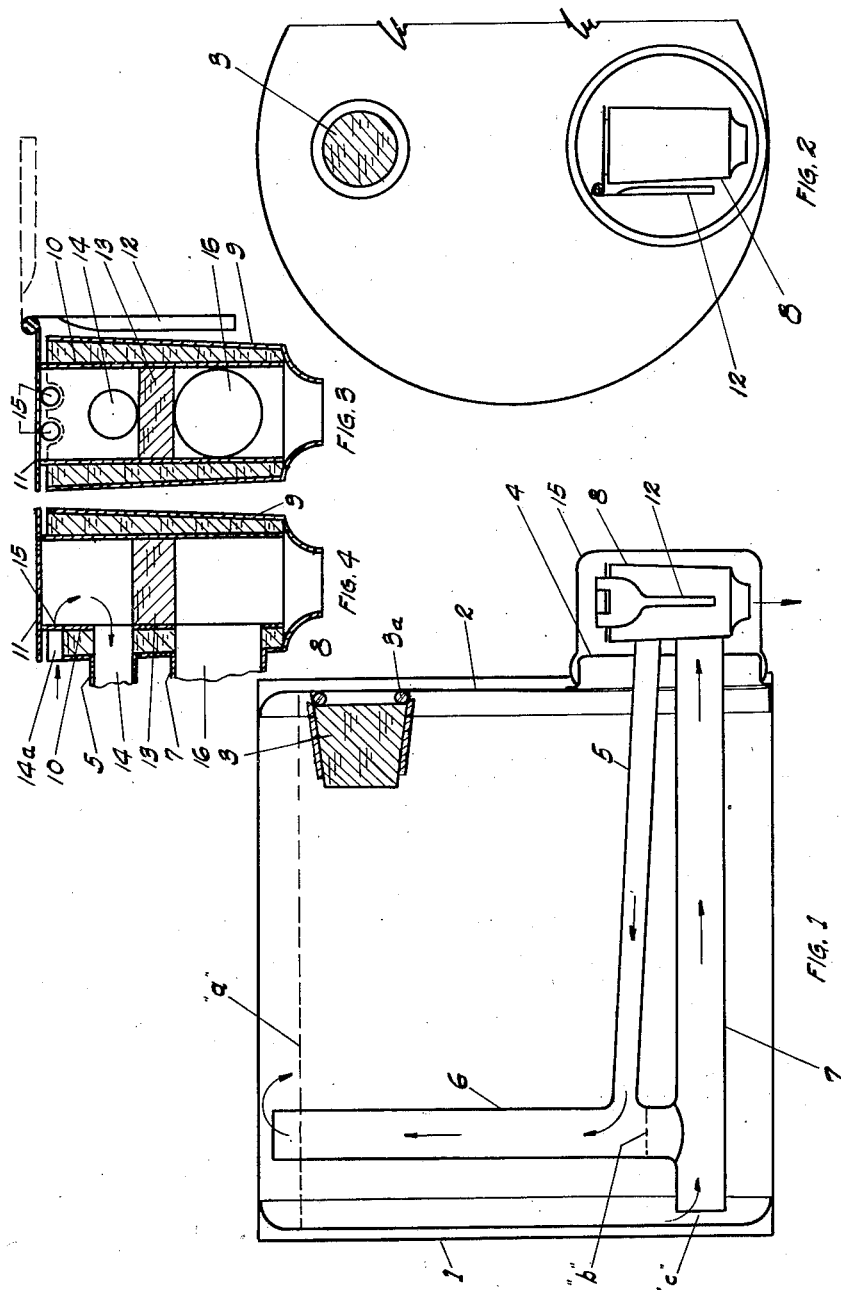

INVENTORS,
Raymond R. Bowser and Jacob Elmer Miltzberger, Jr.,
BY
Howard S. Smith,
Their ATTORNEY

UNITED STATES PATENT OFFICE

2,018,943

LIQUID DISPENSING CONTAINER

Raymond R. Bowser, near Dayton, and Jacob
Elmer Miltenberger, Jr., Dayton, Ohio

Application January 2, 1935, Serial No. 42

7 Claims. (Cl. 225—1)

This invention relates to new and useful improvements in liquid dispensing containers.

In order to withdraw liquids such as beer in bulk quantities from kegs and other containers, it is necessary to punch out a bung, or tap a hole in the container to receive a dispensing pump. However, immediately this hole is made, carbon dioxide gas will escape through it to make that liquid more or less flat for beverage purposes. Furthermore, when a pump is inserted in the hole, air will be discharged therefrom through the liquid, forcing the carbon dioxide gas out of the liquid and introducing therein bacteria and other foreign matter.

If the container holds alcohol or other commercial liquids, the air vent which is drilled or punched in it to release the liquid will become a means through which some of the vapors will escape, thus causing waste.

It is one of the principal objects of our invention to provide a hermetically sealed container from which liquids in bulk quantities may be freely dispensed without waste, contamination or deterioration by automatically introducing air into the receptacle without aerating the liquid therein. If beer is dispensed, carbon dioxide gas is not released, except that held in liquid solution is discharged, nor does the air pass through the liquid to leave therein bacteria and other foreign matter to contaminate it. The container remains hermetically sealed while the air is introduced through the control valve into it to discharge the liquid in a substantially whole and uniform manner through the same valve.

It is another object of our invention to provide a spigot through which air or gas may be introduced into a container, and the liquid withdrawn from it, without that air or gas coming in contact with the liquid in the spigot. The spigot not only admits free air or gas to the container, to displace the fluid, but at the same time discharges that liquid from the container in a controlled or continuous stream free from any bubbles save those caused by the air or gas dissolved within the liquid itself.

Other important and incidental objects will be brought out in the following specification and particularly set forth in the subjoined claims.

In the accompanying drawing illustrating our invention, Figure 1 is a longitudinal sectional view taken through a liquid container in which our fluid dispensing means have been installed. Figure 2 is a front view of said container, showing the spigot for admitting air to, and discharging the liquid from, the container. Figure

3 is a front vertical sectional view taken through the spigot. And Figure 4 is a side, vertical sectional view taken through the same.

Referring to the accompanying drawing for a detailed description of our invention, the numeral 1 designates a can or container 1 filled with a liquid to be dispensed in bulk quantities therefrom. Formed in the head or top 2 of this container is a hole 3, through which the liquid to be dispensed is introduced into the container. This hole is closed by a cork stopper 3 pressed below ribs 3^a to make it non-removable after the container has been filled.

Formed in the head 2 of the container between the filling aperture and a side wall thereof, is a raised portion 4 in which an air inlet aperture and a liquid discharge opening are formed. Projecting through the air inlet aperture in the raised portion 4 of the head 2 is the outer end of a tubular line or projection 5 on the lower end of a tube or standpipe 6 that extends upwardly into the liquid in the container. At its extreme lower end the tube 6 communicates with the inner end portion of a horizontal liquid discharge tube or line 7 that projects with the air line 5 through the liquid discharge opening in the raised portion 4 of the head 2.

The tubes 5, 6 and 7 are preferably made up as an integral structure, to the outer ends of the air and liquid line parts 5 and 7 of which a spigot 8 is attached. This spigot comprises a conical shell 9, open at the bottom and the top, and formed in its circular wall with an upper aperture into which the outer end of the air line 5 is fitted, and with a larger hole below to receive the outer end of the liquid line 7. Rotatably fitted within the shell 9 is a hollow plug 10 having a flanged top 11 to which the shank of a turning ear 12 is hingedly attached. The top portion of the plug 10, which is its air inlet part, is hermetically sealed from its lower, or fluid discharge portion by a horizontal partition 13.

Formed in the wall of the plug 10 above the partition 13 therein, is an air outlet opening 14 which is adapted to be brought into registry with the outer end of the air line 5 by turning the plug.

Air enters the top portion of the plug through a notch 14^a in the top edge of the shell 9, and holes 15 in the plug, flowing therefrom through the outlet hole 14 into the air line 5. The partition 13 prevents this air from coming in contact, in the spigot, with the liquid which is discharged from the lower end of the latter when it

is turned to bring an opening 16 therein in communication with the outer end of the dispensing tube 7.

In operation, the container is shown in a dispensing position in Figure 1, being filled in this instance to the approximate level indicated by the dotted line "a". To dispense liquid from the container, the spigot plug 10 is rotated a quarter turn to bring the opening 16 therein into registry with the liquid line 7, while the opening 14 remains closed, to permit any pressure upon the liquid within the container to be dissipated by allowing the liquid under that pressure to flow through the line into, and out of, the lower end of the spigot.

After this pressure is relieved, the spigot is given another quarter turn to open the air line 5 and liquid line 7 completely, as shown in Figure 4, causing the liquid in the vertical tube 6 to drop to the level "b". The air passing into the line 5 is then permitted to ascend in the tube 6 without passing through the liquid to contaminate the latter with bacteria and other foreign matter. The hydrostatic pressure induced by the admission of this air will force the liquid into the open end c of the liquid dispensing tube 7, from which it will pass through the spigot in a natural flow. If beer is thus dispensed, carbon dioxide gas that would otherwise be lost, will be retained to maintain the flavor of the beverage.

When the spigot is turned off, the liquid, under hydrostatic pressure, will again rise in the tube 6 above its "b" level to seal that tube against the entrance of air from the air line 5, until it is desired to dispense more liquid from the container.

When the container is prepared for shipment, a cup-shaped cover 15 is fitted over the raised portion 4 of the head 2 to protect the spigot from dirt and injury, as well as to provide a sealing means for the container.

Having described our invention, we claim:

1. In a container closed at both ends, a tube projecting through one end of the container toward the other end thereof and open at its inner end to the liquid within the container, a tube projecting upwardly from the first tube at a point near its inner open end, and an air line extending forwardly from the second tube, above, and in the same general direction as, the first tube, for projection through the first-named end of the container, to admit air above the liquid to force it out of the first tube in a natural flow.

2. In a container closed at both ends, a tube projecting through one end of the container toward the other end thereof, and open at its inner end to the liquid within the container, a tube projecting upwardly from the first tube at a point near its open end, an air line extending forwardly from the second tube, above, and in the same general direction as, the first tube, for projection through the first-named end of the container, and a valve attached to the outer ends of the first tube and the air line, through which air is admitted to said line and from which liquid is discharged in a natural flow.

3. In a container including a head, a tube in said container projecting at one end through the head thereof and being open at its other end to the liquid within the container, said tube being horizontally disposed when the container is held in a dispensing position, a tube projecting upwardly from the first tube when the container is held in said position, an air line running from the second tube above, and in the same general direction as the first tube, and projecting with it

through said head, and a valve attached to the outer ends of the first tube and the air line, through which air is admitted to said line and from which liquid is discharged in a natural flow.

4. In a container closed at both ends, a tube projecting through one end of the container toward the other end of the latter, and open at its inner end to the liquid within the container, a tube projecting upwardly from the first tube at a point near its inner open end, an air line projecting forwardly from the second tube, above, and in the same general direction as, the first tube, and a partitioned spigot attached to the outer ends of the first tube and the air line, through the upper portion of which air is admitted to said air line, and from the lower portion of which liquid is discharged free from contact, in said spigot, with the incoming air.

5. A liquid dispensing device comprising a sealed container, a liquid dispensing pipe in the container and provided with an open inner end, the opposite end of the pipe projecting exteriorly of the container, a tube inside the container in communication with and extending outwardly of said dispensing pipe, the outer end of the tube being open and being adapted when the container is in dispensing condition to be disposed above the liquid level, and an air line in the container with its inner end communicating with said tube and its outer end extending exteriorly of the container for admitting air above the liquid in the container for forcing the liquid outwardly of said dispensing pipe.

6. A liquid storage and dispensing device comprising a sealed container, a liquid dispensing pipe in the container and provided with an open inner end, the opposite end of the pipe projecting exteriorly of the container, a tube inside the container in communication with and extending outwardly of said dispensing pipe, the outer end of the tube being open and being adapted when the container is in dispensing position to be disposed above the liquid level, an air line in the container with its inner end communicating with said tube and its outer end extending exteriorly of the container, and means associated with the outer ends of said pipe and line for opening and closing said outer ends independently of one another whereby the dispensing pipe alone may be opened for initially dispensing liquid by the pressure created by the liquid itself and the air line subsequently opened for passing air, through said tube and independently of the body of the liquid, to the space above the liquid level for forcing the liquid outwardly of the dispensing pipe.

7. A liquid dispensing device comprising a closed container, a dispensing pipe projecting into the container, a tube communicating with and projecting upwardly of the dispensing pipe interiorly of the container, an air line projecting into the container and communicating with said tube, and means associated with the outer ends of said dispensing pipe and air line for initially dispensing the liquid by force of the pressure within the container and for subsequently admitting air above the liquid level in the container for dispensing the liquid, the admission of air effecting lowering of the liquid in said tube to a point below the communication of said tube with the air line whereby the air may be introduced above the liquid level to prevent aeration of the contained liquid.

RAYMOND R. BOWSER.

JACOB ELMER MILTENBERGER, JR.